

Válvula de paso anular Riko® DN 150 – DN 1600 PN 10... 100



VAG-
Armaturen
GmbH

VAG Riko® - Plunger Valve DN 150 – DN 1600 PN 10... 100

VAG

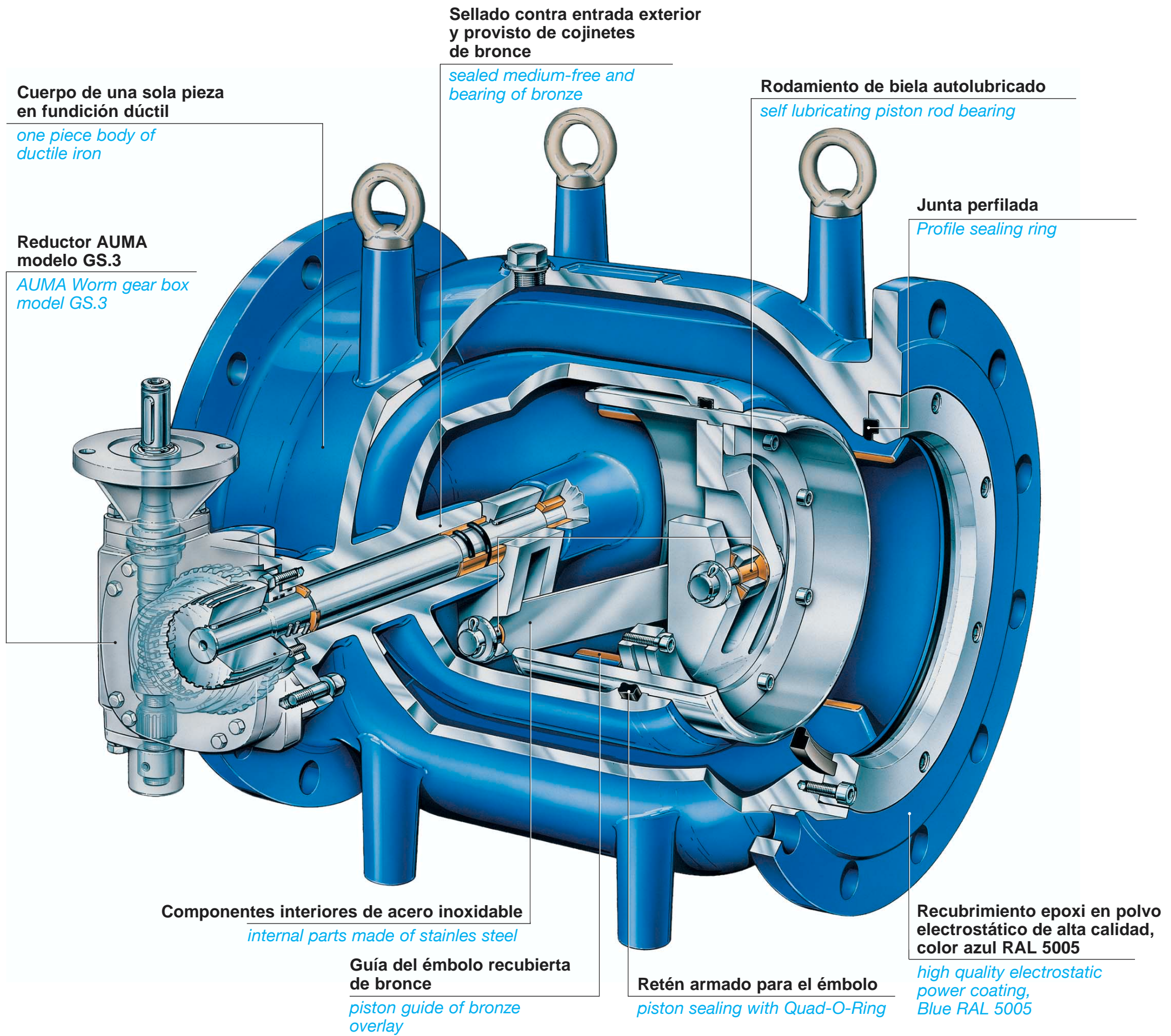

Bocas de salida: *Outlets:*

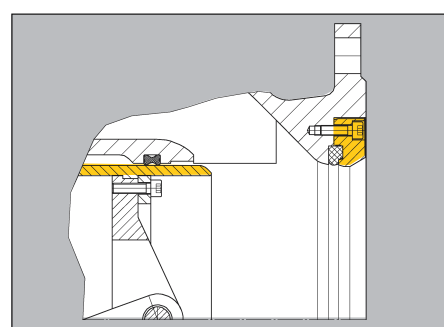

Asiento tipo E
Seat type E

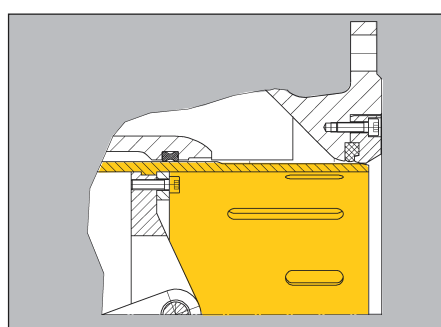

Tipo SZ con camisa ranurada
Type SZ with slotted cylinder

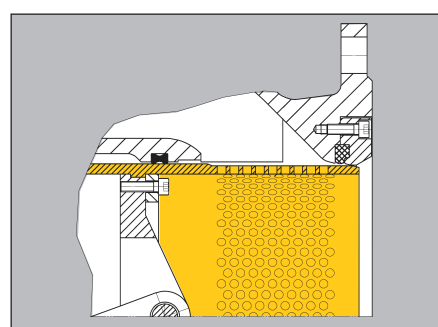

Tipo LH con camisa perforada
Typ LH with anti cavitational multiple orifice cylinder

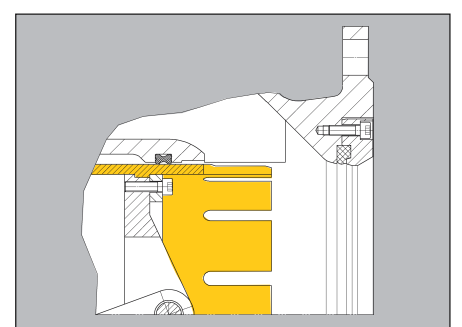

Diseños especiales
Special designs